

ORDER REFERENCE

PROJECT: UC601 OVERHEAD CABLE DRUM  
TYPICAL LAYOUT

PLEASE REFER TO THE PLANNING  
GUIDE FOR ADDITIONAL SIZING  
AND GATE OPTIONS

OVERHEAD CABLE DRUM  
OFFERS A MAXIMUM OF:  
6 STOPS  
40'-0" OF TRAVEL  
15 SQ. FT. CAB SIZE

SPECIFICATIONS

DRIVE: UC601 OVERHEAD CABLE DRUM

CAPACITY: 1000#

LANDINGS: 3

MANUFACTURED TO MEET:  
ASME A17.1 – 2016  
IT IS THE RESPONSIBILITY OF THE INSTALLER OF THE UNIT  
TO SATISFY ASME, NEC, STATE, AND LOCAL BUILDING CODES

CODE(S): 4 (INCLINATOR LAYOUT DESIGN)

SPEED: AT 38 F.P.M. ±2

SUSPENSION MEANS: (2) STEEL WIRE ROPES 12,100#  
BREAKING STRENGTH  $\phi 3/8$  – 8 x 19 IWRC

CAR STYLE: 200 STYLE

CAR CONSTRUCTION: 3/4" HARDWOOD VENEER

NOTE: ALL MANUFACTURER SUPPLIED CAR AND EQUIPMENT OPTIONS ARE  
NOTED ON THE CONFIRMING ORDER SHEET.

DISCLAIMER: ONCE DRAWINGS HAVE BEEN APPROVED,  
SIGNED AND WITHIN 5 DAYS OF PRODUCTION, THE  
CUSTOMER WILL BEAR ALL RESPONSIBILITY AND LIABILITY  
OF FINISHED UNIT.

		PROJECT TYPICAL UC601 OHCD				REVISION DATE 11/2017	
		DRAWING VIEW COVER SHEET		DRAWING TEMPLATE NO. 80211292 – REV –		4/2021	
PAGE: 1/7	DRAWN BY: S THOMAS	DATE 3/2017	JOB NO. TYP-OHCD-115	DEALER P.O. NO. –	SCALE NTS	REVISION LEVEL B	

PROJECT:  
UC601 OVERHEAD CABLE DRUM  
TYPICAL LAYOUT

MANUFACTURED TO MEET:  
ASME A17.1 – 2016  
IT IS THE RESPONSIBILITY OF THE INSTALLER OF THE UNIT  
TO SATISFY ASME, NEC, STATE, AND LOCAL BUILDING CODES

INSTALLED BY:  
-

NOT TO BE USED FOR CONSTRUCTION  
TYPICAL DRAWING

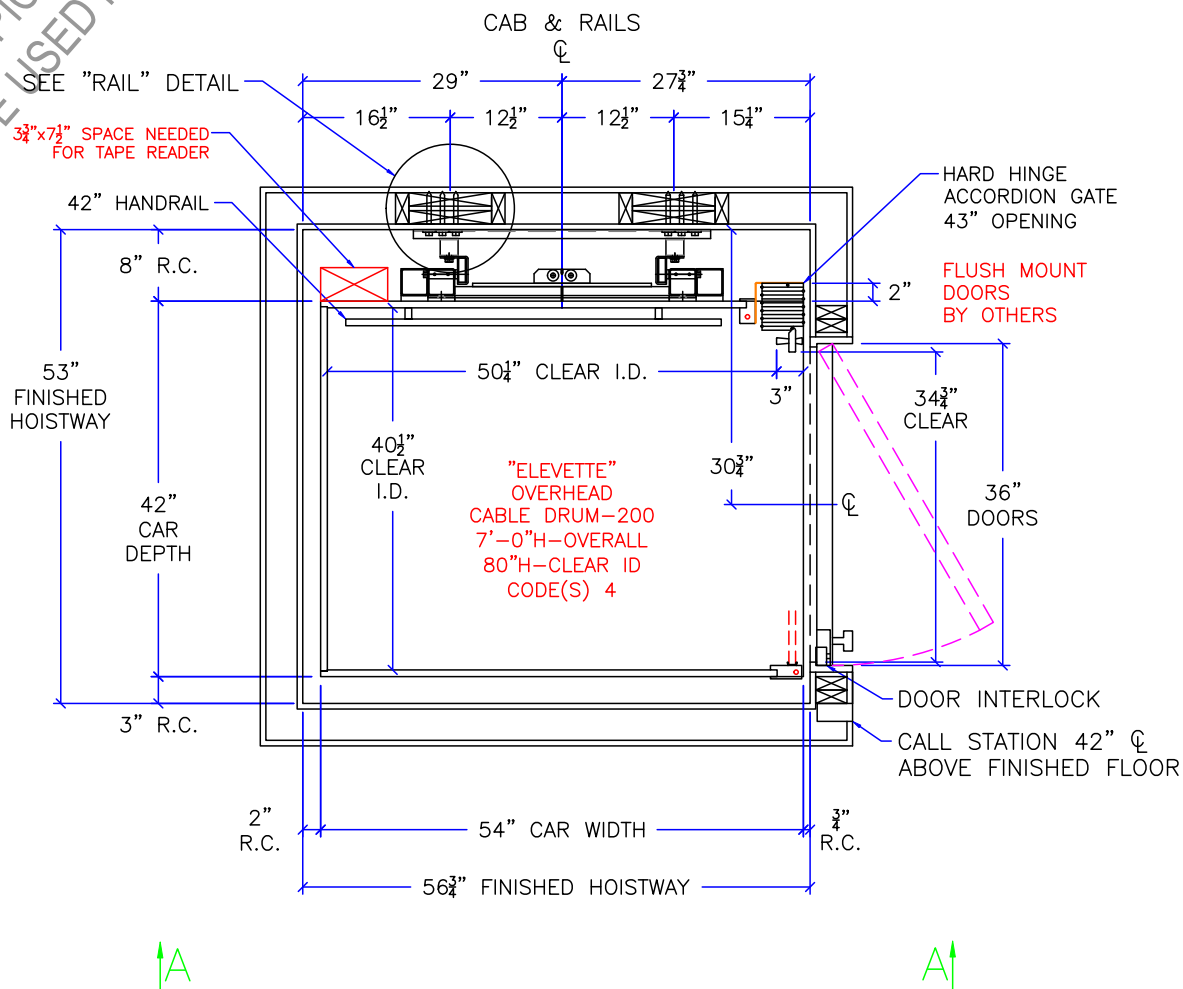

NOTE:  
ALL HOISTWAY CONSTRUCTION MUST COMPLY WITH NATIONAL, STATE,  
AND LOCAL CODES. HOISTWAY MUST BE PLUMB AND STRAIGHT  
FROM TOP TO BOTTOM WITH NO PROJECTIONS INTO THE HOISTWAY.



PROJECT					TYPICAL UC601 OHCD		REVISION DATE
DRAWING VIEW					HOISTWAY LAYOUT		11/2017
PAGE:					DRAWING TEMPLATE NO.		4/2021
2/7	DRAWN BY:	DATE	JOB NO.	DEALER P.O. NO.	SCALE	REVISION LEVEL	-
	S THOMAS	3/2017	TYP-OHCD-115	-	NTS	B	-

PROJECT:  
UC601 OVERHEAD CABLE DRUM  
TYPICAL LAYOUT

MANUFACTURED TO MEET:  
ASME A17.1 – 2016  
IT IS THE RESPONSIBILITY OF THE INSTALLER OF THE UNIT  
TO SATISFY ASME, NEC, STATE, AND LOCAL BUILDING CODES

INSTALLED BY:  
-

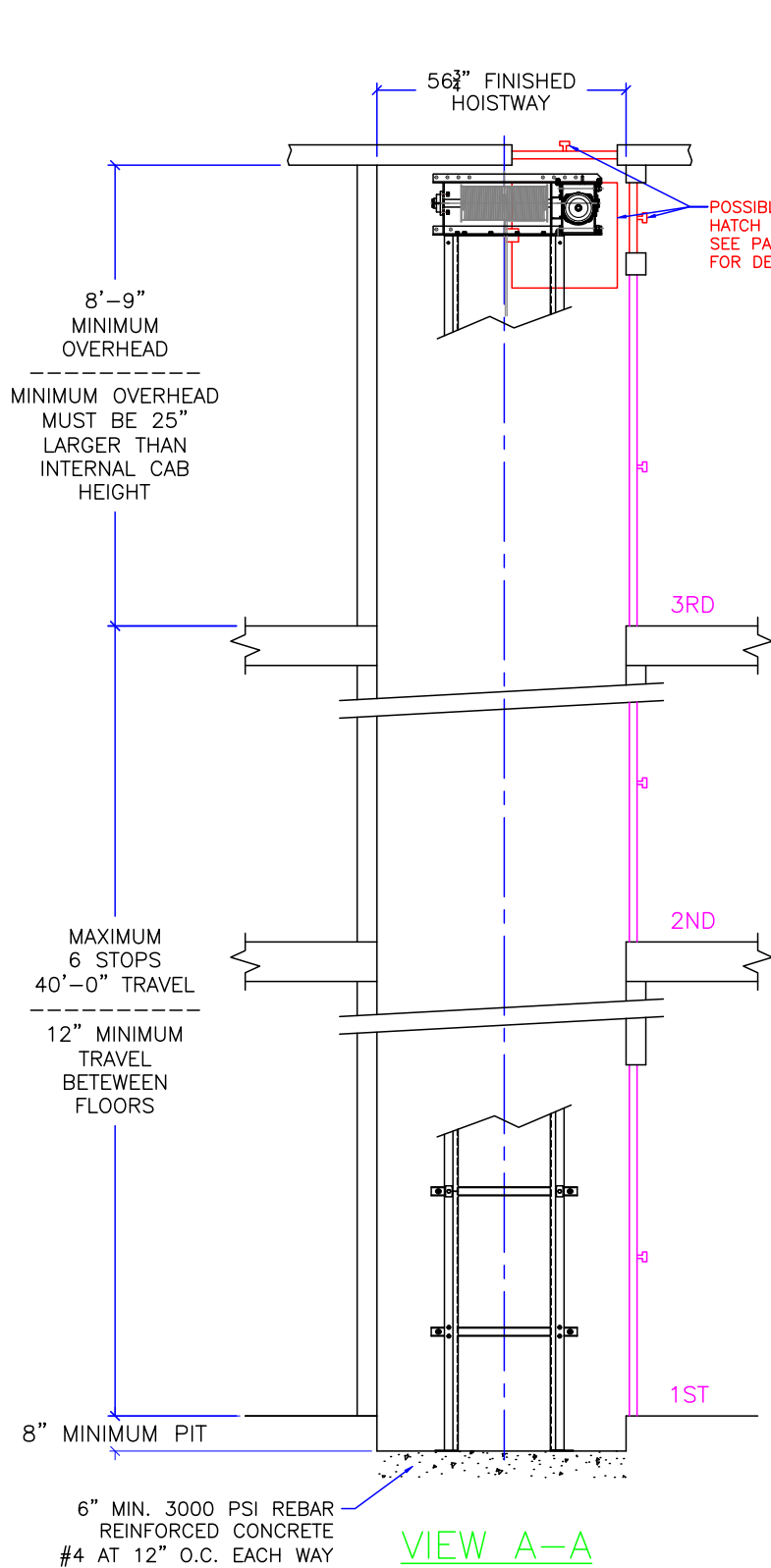

RECOMMENDED BEAM ABOVE  
HOISTWAY CAPABLE OF  
SUPPORTING UP TO 1000 LBS.  
FOR LIFTING POWER UNIT.

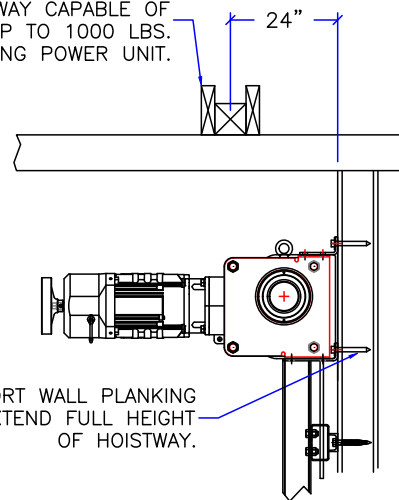

NOTE:  
MAX 24" x 24" ACCESS  
DOOR/HATCH MUST HAVE  
SPRING-TYPE LOCK AND  
ELECTRIC SWITCH WIRED  
INTO CONTROLLER SAFETY  
CIRCUIT.

NOT TO BE USED FOR CONSTRUCTION  
TYPICAL DRAWING

PIT FLOOR REACTIONS  
LOAD ON BUFFERS – 3500 LBS  
STATIC LOAD – 2400 LBS

PIT FLOOR TO HAVE A SMOOTH  
TROWEL FINISH FREE OF HOLLOW  
OR BUMPS. SURFACE TO BE LEVEL  
AND FLAT TO WITHIN  $\pm \frac{1}{8}$  IN ANY  
DIRECTION



PROJECT				TYPICAL UC601 OHCD			REVISION DATE		
DRAWING VIEW				SECTION A-A			11/2017		
PAGE: 3/7				DRAWN BY: S THOMAS		DATE: 3/2017		DRAWING TEMPLATE NO. 80211292 – REV –	
JOB NO. TYP-OHCD-115		DEALER P.O. NO. –		SCALE NTS		REVISION LEVEL B			

PROJECT:  
UC601 OVERHEAD CABLE DRUM  
TYPICAL LAYOUT

MANUFACTURED TO MEET:  
ASME A17.1 – 2016  
CONTROL ROOM MUST MEET ALL LOCAL, STATE, AND NATIONAL CODES  
INCLUDING ALL APPLICABLE NEC CODE REQUIREMENTS

INSTALLED BY:  
—

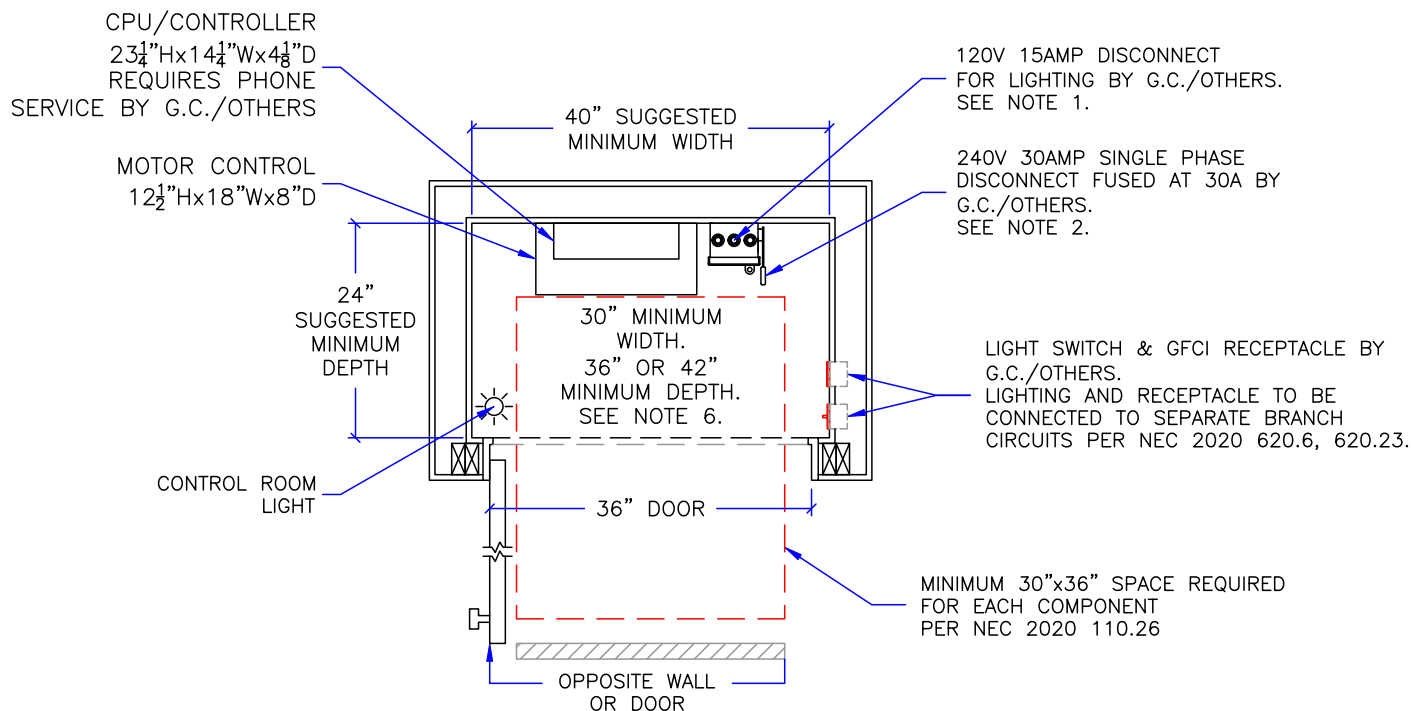

**CONTROL ROOM NOTES:**

- ELEVATOR CAB LIGHTING RECEPTACLE & ACCESSORIES: 120V 15 AMP EXTERNALLY OPERABLE FUSED LOCKABLE DISCONNECT SWITCH BY G.C./OTHERS PER NEC 2020 620.22, 620.53.
- 240V 30 AMP EXTERNALLY OPERABLE FUSED LOCKABLE DISCONNECT SWITCH BY G.C./OTHERS PER NEC 2020 620.51, 430.110. FUSE TO BE 30A TYPE FRN-R CLASS RK5 OR EQUIVALENT. 30A SUGGESTED BREAKER SIZE FOR POWER TO DISCONNECT.
- IT IS RECOMMENDED THAT THE CPU AND MOTOR CONTROL BE INSTALLED IN THE SAME LOCATION. THE RECOMMENDED WIRING DISTANCE FROM THE CPU TO MOTOR CONTROL UNIT IS 5'. LONGER CABLES UP TO 40' ARE AVAILABLE. CONSULT WITH INCLINATOR WHEN ORDERING.
- CPU AND MOTOR CONTROL SHOULD BE MOUNTED IN A TEMPERATURE CONTROLLED ENVIRONMENT BETWEEN 40°F TO 120°F (4°C – 49°C).
- CPU AND MOTOR CONTROL SHOULD NOT BE EXPOSED TO OUTDOOR ELEMENTS.
- SPACE REQUIREMENTS (INDIVIDUALLY) IN FRONT OF CPU, MOTOR CONTROL, AND DISCONNECTS (REFERENCE NEC 2020 110.26):  
 WIDTH: THE WIDTH OF THE CONTROLLERS OR 30", WHICHEVER IS GREATER  
 DEPTH: 36" IF THE OPPOSITE WALL OR DOOR IS NOT CONCRETE, BRICK, TILE OR A METALLIC DOOR.  
 42" IF THE OPPOSITE WALL OR DOOR IS CONCRETE, BRICK, TILE OR A METALLIC DOOR.  
 HEIGHT: MINIMUM 6'-6" FROM GRADE, FLOOR, OR PLATFORM, OR THE HEIGHT OF THE CONTROLLERS, WHICHEVER IS GREATER
- CONTROL ROOM TO HAVE NATURAL/MECHANICAL VENTILATION IF REQUIRED BY STATE OR LOCAL CODES.
- ALL MEANS FOR ACCESS TO EQUIPMENT SHALL BE PROVIDED WITH A LOCK.

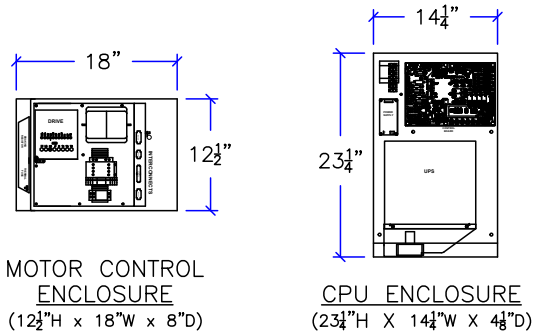

**NOTICE TO ELECTRICAL CONTRACTOR:**

- ALL ELECTRICAL WIRING MUST BE DONE BY A JOURNEYMAN ELECTRICIAN AND MUST MEET ALL NATIONAL, STATE, AND LOCAL CODES.
- BRING (2) #10 W/GND, ASSUMING 30A BREAKER, FROM RESIDENCE INCOMING POWER PANEL (240V, & GROUND) TO THE CONTROL ROOM.
- BRING (2) #12 W/GND FROM RESIDENCE INCOMING POWER PANEL (120V, NEUTRAL, GROUND) TO THE CONTROL ROOM.
- ALL REQUIRED LOW VOLTAGE WIRING IS SUPPLIED BY INCLINATOR. LOW VOLTAGE WIRING MUST NOT BE EXTENDED OR SPLICED. LONGER CABLES CAN BE PURCHASED FROM INCLINATOR IF NECESSARY.
- AN ANALOG TELEPHONE LINE SHALL BE SUPPLIED TO THE MACHINE ROOM AND SHALL BE CONNECTED TO A 24 HOUR CENTRAL EXCHANGE. THE ELEVATOR PHONE WILL NOT FUNCTION WITH STANDARD DIGITAL/VOIP SERVICE WITHOUT A DIGITAL TO ANALOG CONVERTER.

	PROJECT					REVISION DATE	
	TYPICAL UC601 OHCD					11/2017	
	DRAWING VIEW					4/2021	
CONTROL ROOM REQUIREMENTS					DRAWING TEMPLATE NO.		
					80211292 – REV –		
PAGE:	DRAWN BY:	DATE	JOB NO.	DEALER P.O. NO.	SCALE	REVISION LEVEL	
4/7	S THOMAS	3/2017	TYP-OHCD-115	–	NTS	B	

PROJECT:  
UC601 OVERHEAD CABLE DRUM  
TYPICAL LAYOUT

MANUFACTURED TO MEET:  
ASME A17.1 – 2016  
CONTROL SPACE MUST MEET ALL LOCAL, STATE, AND NATIONAL CODES  
INCLUDING ALL APPLICABLE NEC CODE REQUIREMENTS

INSTALLED BY:  
-

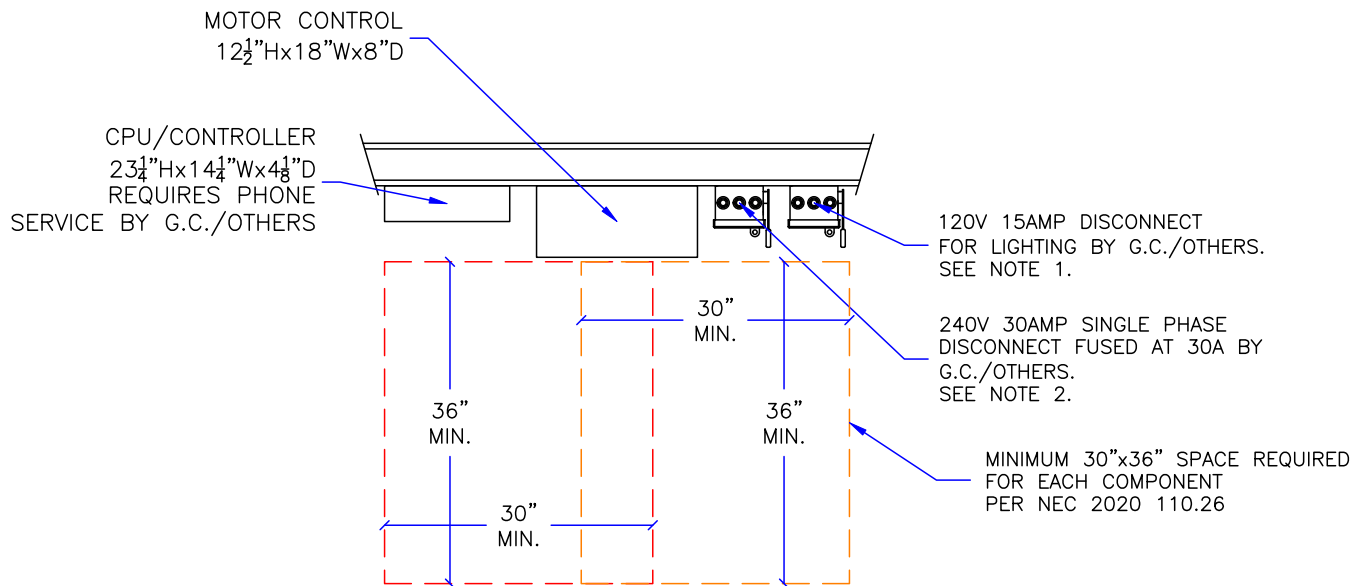

**CONTROL SPACE NOTES:**

- ELEVATOR CAB LIGHTING RECEPTACLE & ACCESSORIES: 120V 15 AMP EXTERNALLY OPERABLE FUSED LOCKABLE DISCONNECT SWITCH BY G.C./OTHERS PER NEC 2020 620.22, 620.53.
- 240V 30 AMP EXTERNALLY OPERABLE FUSED LOCKABLE DISCONNECT SWITCH BY G.C./OTHERS PER NEC 2020 620.51, 430.110. FUSE TO BE 30A TYPE FRN-R CLASS RK5 OR EQUIVALENT. 30A SUGGESTED BREAKER SIZE FOR POWER TO DISCONNECT.
- IT IS RECOMMENDED THAT THE CPU AND MOTOR CONTROL BE INSTALLED IN THE SAME LOCATION. THE RECOMMENDED WIRING DISTANCE FROM THE CPU TO MOTOR CONTROL UNIT IS 5'. LONGER CABLES UP TO 40' ARE AVAILABLE. CONSULT WITH INCLINATOR WHEN ORDERING.
- CPU AND MOTOR CONTROL SHOULD BE MOUNTED IN A TEMPERATURE CONTROLLED ENVIRONMENT BETWEEN 40°F TO 120°F (4°C – 49°C).
- CPU AND MOTOR CONTROL SHOULD NOT BE EXPOSED TO OUTDOOR ELEMENTS.
- SPACE REQUIREMENTS (INDIVIDUALLY) IN FRONT OF CPU, MOTOR CONTROL, AND DISCONNECTS (REFERENCE NEC 2020 110.26):  
 WIDTH: THE WIDTH OF THE CONTROLLERS OR 30", WHICHEVER IS GREATER  
 DEPTH: 36" IF THE OPPOSITE WALL OR DOOR IS NOT CONCRETE, BRICK, TILE OR A METALLIC DOOR.  
 42" IF THE OPPOSITE WALL OR DOOR IS CONCRETE, BRICK, TILE OR A METALLIC DOOR.  
 HEIGHT: MINIMUM 6'-6" FROM GRADE, FLOOR, OR PLATFORM, OR THE HEIGHT OF THE CONTROLLERS, WHICHEVER IS GREATER
- CONTROL SPACE TO HAVE NATURAL/MECHANICAL VENTILATION IF REQUIRED BY STATE OR LOCAL CODES.
- ALL MEANS FOR ACCESS TO EQUIPMENT SHALL BE PROVIDED WITH A LOCK.

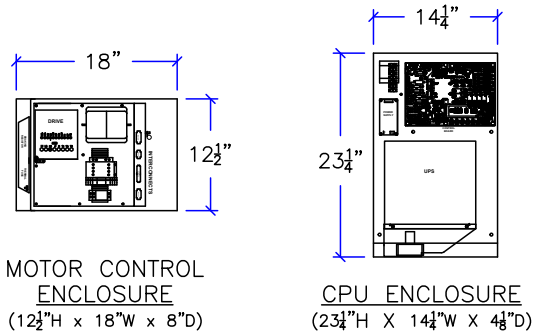

**NOTICE TO ELECTRICAL CONTRACTOR:**

- ALL ELECTRICAL WIRING MUST BE DONE BY A JOURNEYMAN ELECTRICIAN AND MUST MEET ALL NATIONAL, STATE, AND LOCAL CODES.
- BRING (2) #10 W/GND, ASSUMING 30A BREAKER, FROM RESIDENCE INCOMING POWER PANEL (240V, & GROUND) TO THE CONTROL SPACE.
- BRING (2) #12 W/GND FROM RESIDENCE INCOMING POWER PANEL (120V, NEUTRAL, GROUND) TO THE CONTROL SPACE.
- ALL REQUIRED LOW VOLTAGE WIRING IS SUPPLIED BY INCLINATOR. LOW VOLTAGE WIRING MUST NOT BE EXTENDED OR SPLICED. LONGER CABLES CAN BE PURCHASED FROM INCLINATOR IF NECESSARY.
- AN ANALOG TELEPHONE LINE SHALL BE SUPPLIED TO THE MACHINE ROOM AND SHALL BE CONNECTED TO A 24 HOUR CENTRAL EXCHANGE. THE ELEVATOR PHONE WILL NOT FUNCTION WITH STANDARD DIGITAL/VOIP SERVICE WITHOUT A DIGITAL TO ANALOG CONVERTER.

	PROJECT					REVISION DATE	
	TYPICAL UC601 OHCD					11/2017	
	DRAWING VIEW					4/2021	
CONTROL SPACE REQUIREMENTS					DRAWING TEMPLATE NO.		
					80211292 – REV –		
PAGE:	DRAWN BY:	DATE	JOB NO.	DEALER P.O. NO.	SCALE	REVISION LEVEL	
5/7	S THOMAS	3/2017	TYP-OHCD-115	-	NTS	B	

PROJECT:  
UC601 OVERHEAD CABLE DRUM  
TYPICAL LAYOUT

MANUFACTURED TO MEET:  
ASME A17.1 – 2016  
IT IS THE RESPONSIBILITY OF THE INSTALLER OF THE UNIT  
TO SATISFY ASME, NEC, STATE, AND LOCAL BUILDING CODES

INSTALLED BY:  
-

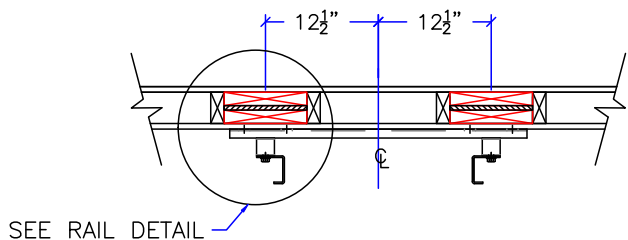

RAIL WALL DETAIL

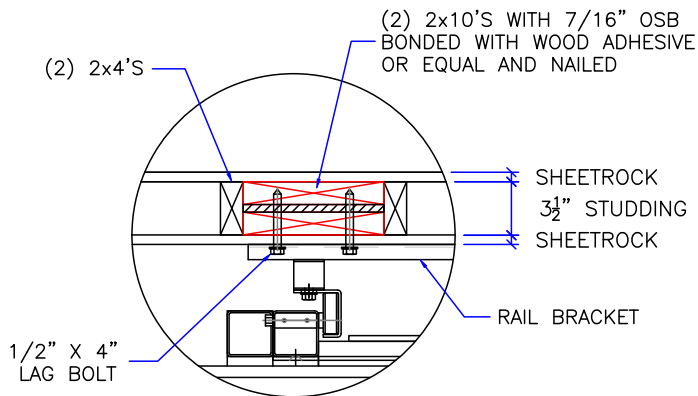

RAIL DETAIL

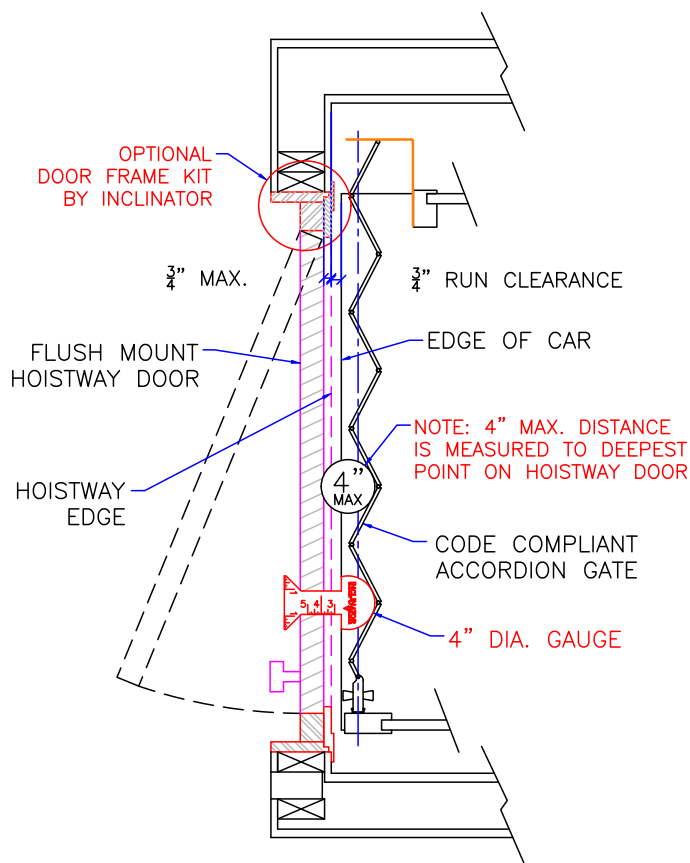

DOOR FRAME DETAILS

REF: ASME 17.1-2016 5.3.1.4.2, 5.3.1.7.2, & 5.3.1.8.3

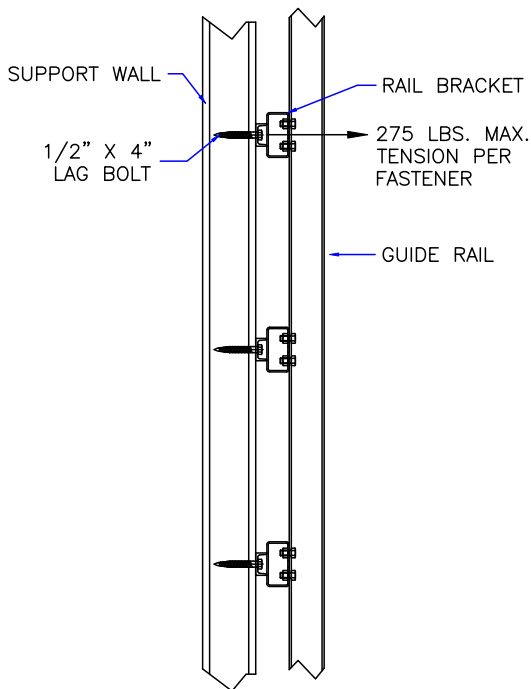

SUPPORT BRACKET PULL OUT



PROJECT		TYPICAL UC601 OHCD			REVISION DATE	
DRAWING VIEW		DETAILS, DATA, CODES			11/2017	
PAGE:	DRAWN BY:	DATE	JOB NO.	DRAWING TEMPLATE NO.	SCALE	REVISION LEVEL
6/7	S THOMAS	3/2017	TYP-OHCD-115	80211292 - REV -	NTS	B
				DEALER P.O. NO.		
				-		

PROJECT:  
UC601 OVERHEAD CABLE DRUM  
TYPICAL LAYOUT

MANUFACTURED TO MEET:  
ASME A17.1 – 2016  
IT IS THE RESPONSIBILITY OF THE INSTALLER OF THE UNIT  
TO SATISFY ASME, NEC, STATE, AND LOCAL BUILDING CODES

INSTALLED BY:  
-

MAX 24" x 24" ACCESS  
DOOR/HATCH MUST  
HAVE SPRING-TYPE  
LOCK AND ELECTRIC  
SWITCH WIRED INTO  
CONTROLLER SAFETY  
CIRCUIT.

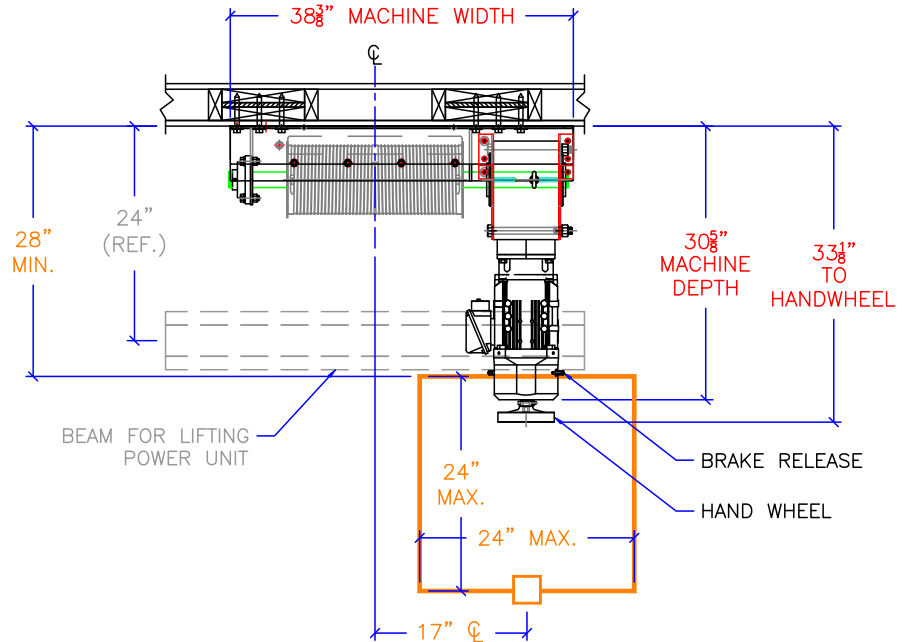

ACCESS DOOR/HATCH  
SHOULD BE POSITIONED  
TO PROVIDE PROPER  
ACCESS TO THE BRAKE  
RELEASE AND HANDWHEEL.

ACCESS DOOR/HATCH (CEILING)

ACCESS DOOR/HATCH  
SHOULD BE POSITIONED  
TO PROVIDE PROPER  
ACCESS TO THE BRAKE  
RELEASE AND HANDWHEEL.

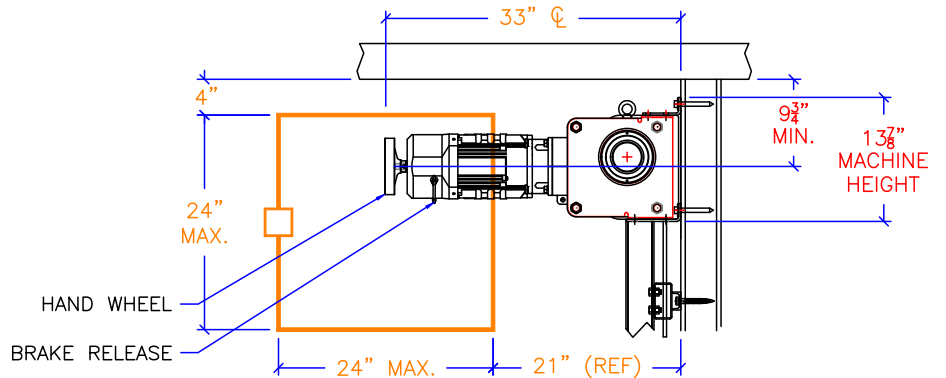

ACCESS DOOR/HATCH (EAST WALL)

ACCESS DOOR/HATCH  
SHOULD BE POSITIONED  
TO PROVIDE PROPER  
ACCESS TO THE BRAKE  
RELEASE AND HANDWHEEL.

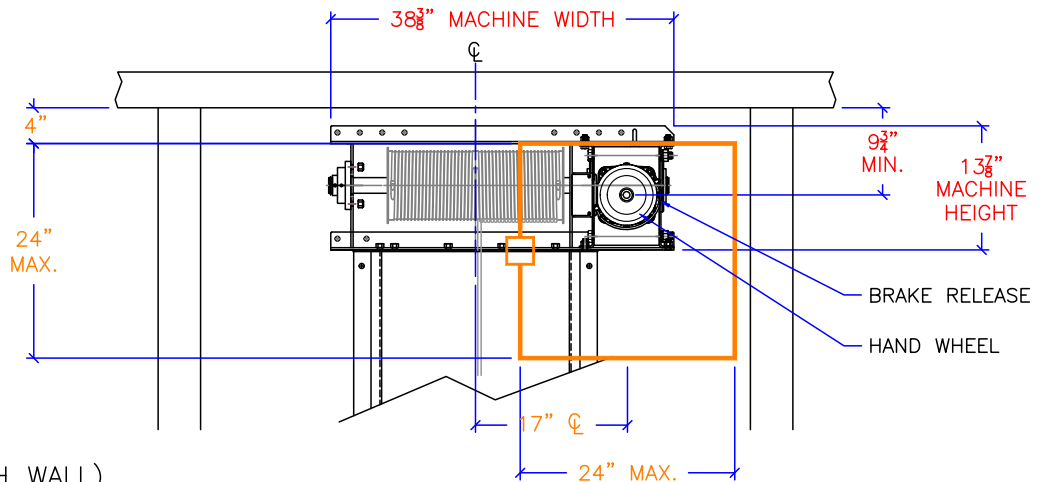

ACCESS DOOR/HATCH (SOUTH WALL)



PROJECT		TYPICAL UC601 OHCD				REVISION DATE	
DRAWING VIEW		POSSIBLE ACCESS PANEL LOCATIONS				DRAWING TEMPLATE NO.	
PAGE:		DRAWN BY:		DATE		JOB NO.	
7/7		S THOMAS		3/2017		TYP-OHCD-115	
DEALER P.O. NO.		SCALE		REVISION LEVEL		-	
-		NTS		B		-	

PROJECT:  
UC601 OVERHEAD CABLE DRUM  
TYPICAL LAYOUT

MANUFACTURED TO MEET:  
ASME A17.1 – 2016  
IT IS THE RESPONSIBILITY OF THE INSTALLER OF THE UNIT  
TO SATISFY ASME, NEC, STATE, AND LOCAL BUILDING CODES

INSTALLED BY:  
-

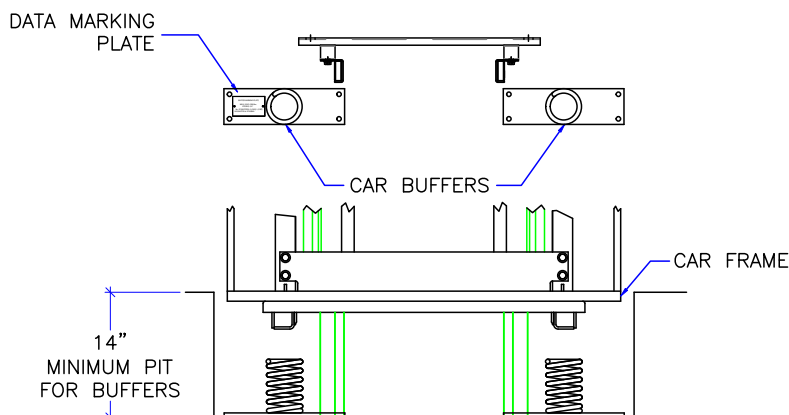

**SPRING BUFFERS**  
SPRING WILL DEPRESS  
1" AT 373 LBS.  
(MANUFACTURERS  
SPECIFICATION)

**BUFFER OPTION**

MANDATORY WHEN OCCUPIABLE SPACE BELOW ELEVATOR

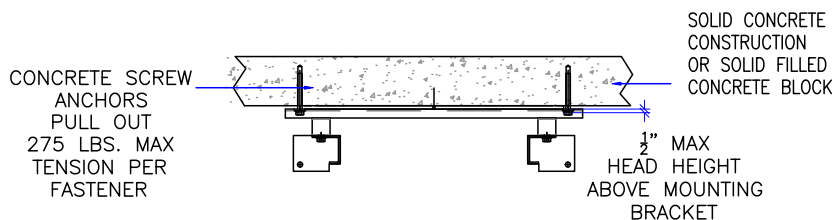

**SOLID CONCRETE**

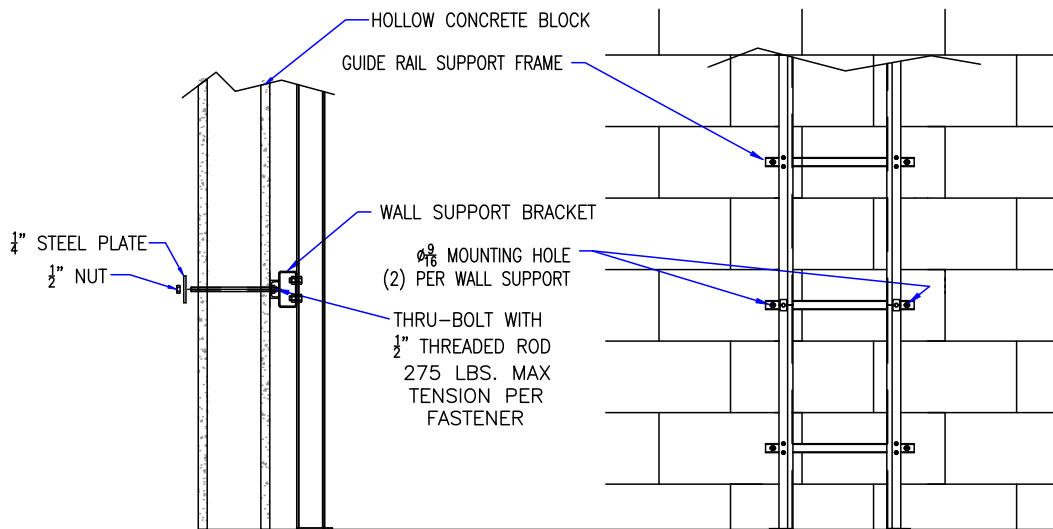

**HOLLOW CONCRETE**



PROJECT		TYPICAL UC601 OHCD			REVISION DATE	
DRAWING VIEW		OPTIONS			11/2017	
PAGE: AUX1		DRAWN BY: S THOMAS		DATE: 3/2017		DRAWING TEMPLATE NO. 80211292 - REV -
JOB NO. TYP-OHCD-115		DEALER P.O. NO. -		SCALE NTS		REVISION LEVEL B
						4/2021
						-



PROJECT:  
UC601 OVERHEAD CABLE DRUM  
TYPICAL LAYOUT

MANUFACTURED TO MEET:  
ASME A17.1 – 2016  
IT IS THE RESPONSIBILITY OF THE INSTALLER OF THE UNIT  
TO SATISFY ASME, NEC, STATE, AND LOCAL BUILDING CODES

INSTALLED BY:  
-

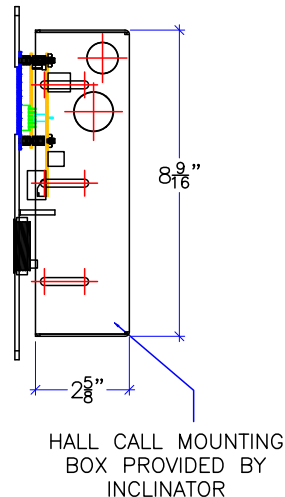
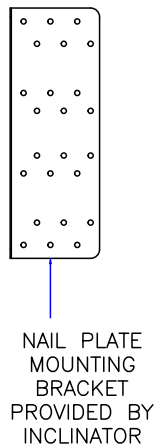
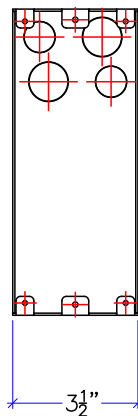
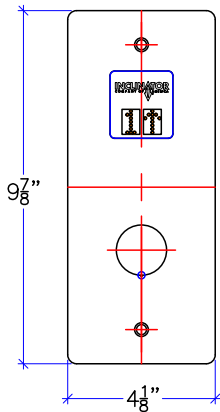
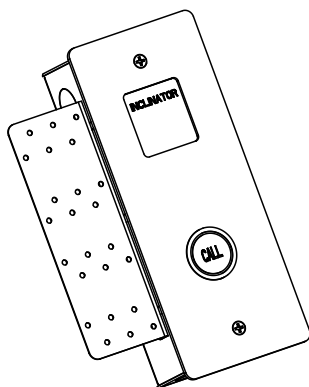

## FLUSH MOUNT HALL CALL STATION

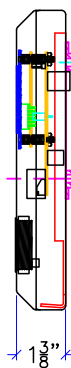
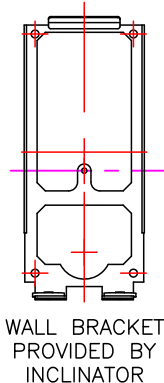
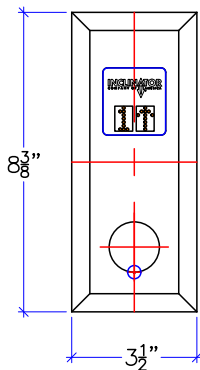
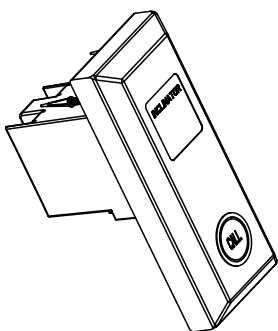

SINGLE GANG  
MOUNT ELECTRICAL  
BOX BY OTHERS

THIS HOLE USED  
TO LOCATE BRACKET  
OVER GANG BOX

## RAISED MOUNT HALL CALL STATION



PROJECT		TYPICAL UC601 OHCD				REVISION DATE	
DRAWING VIEW		CALL STATIONS				11/2017	
PAGE:		DRAWN BY:		DATE		DRAWING TEMPLATE NO.	
AUX2	S THOMAS	3/2017		JOB NO.		80211292 – REV –	
DEALER P.O. NO.		SCALE		REVISION LEVEL		-	
-		NTS		B		-	

PROJECT:  
UC601 OVERHEAD CABLE DRUM  
TYPICAL LAYOUT

MANUFACTURED TO MEET:  
ASME A17.1 – 2016  
IT IS THE RESPONSIBILITY OF THE INSTALLER OF THE UNIT  
TO SATISFY ASME, NEC, STATE, AND LOCAL BUILDING CODES

INSTALLED BY:  
-

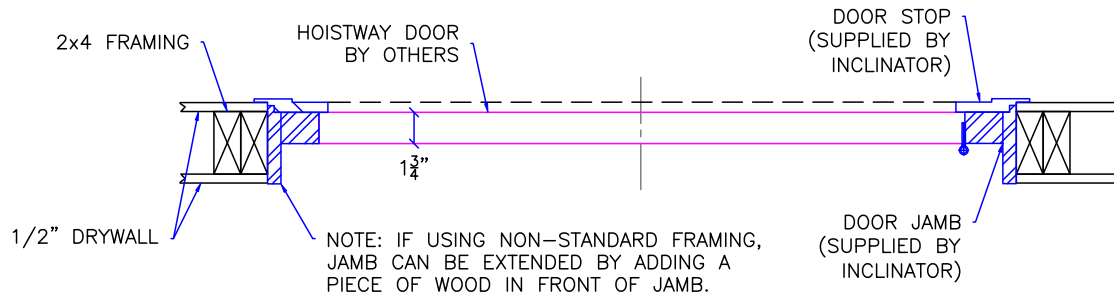

**DOOR FRAME DETAIL**  
STANDARD 2x4 CONSTRUCTION WITH  
1/2" DRYWALL (INSIDE & OUTSIDE OF HOISTWAY)

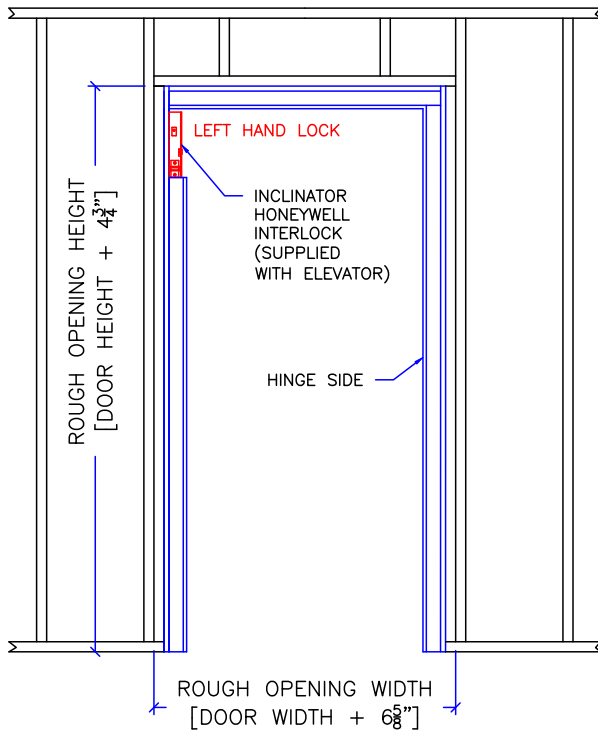

**HALLWAY VIEW**

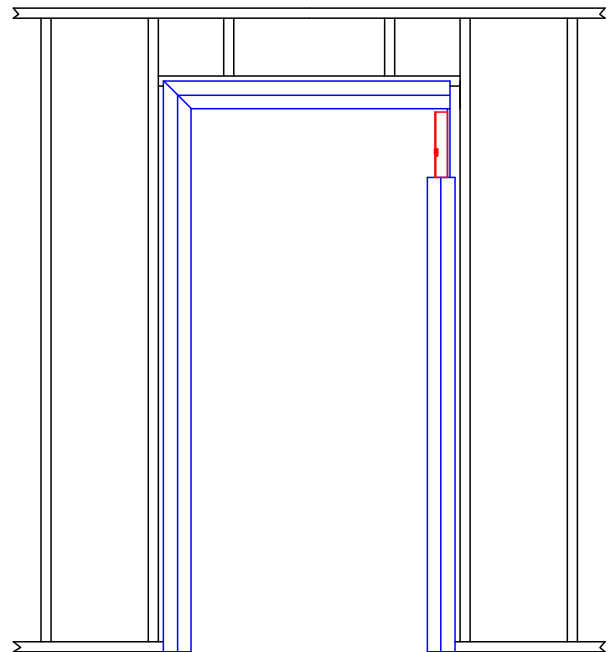

**HOISTWAY VIEW**



PROJECT		TYPICAL UC601 OHCD				REVISION DATE	
DRAWING VIEW		FLUSH MOUNT DOOR FRAME KIT				11/2017	
PAGE: AUX3		DRAWN BY: S THOMAS		DATE: 3/2017		DRAWING TEMPLATE NO. 80211292 - REV -	
JOB NO. TYP-OHCD-115		DEALER P.O. NO. -		SCALE NTS		REVISION LEVEL B	